



VALVCHEQ BACKFLOW PREVENTERS

FIGURE SC03

Testable single check valve for low hazard rated applications
Flanged and roll grooved connections



FEATURES

- Short body length to allow the replacement of conventional non-testable check valves.
- Supplied with lifting lugs to assist with installation.
- Compact simple design.
- In-line and on-site serviceable.
- No special tools required for servicing.
- Designed and manufactured in accordance with requirements of AS/NZS 2845.1.
- FBE coated to AS/NZS 4158.
- Straight through flow path for maximum flow co-efficient.
- Top entry allows all parts to be accessed easily.
- Stainless steel internals for superior corrosion resistance.
- Fully restrained check valve assemblies for unrivalled safety.
- Each valve is factory bench tested and tracked with unique serial number.
- All internal components are repairable or replaceable.
- All internal and external bolting is stainless steel.
- Installations can be vertical and horizontal.
- Conforms to the testing requirements of AS/NZS 2845.3.
- Anti-tamper test taps provided as standard.
- Assembly can be supplied with lockable isolating valves.

GENERAL APPLICATION

The SC03 provides low hazard protection from both backsiphonage and backpressure of the potable water supply in fire system applications.

TECHNICAL DATA

Size range: DN 80 to 150
Temperature rating: 1°C to 60°C
Working pressure: PN 16
End connections: Flanged AS 4087
Flanged AS 2129
Roll grooved AS 2638
Alternative flange drillings may be available on request.

WLF AS/NZS 2845.1 Lic WMKA 1324
SAI Global



VALVCEO BACKFLOW PREVENTERS

FIGURE SC03

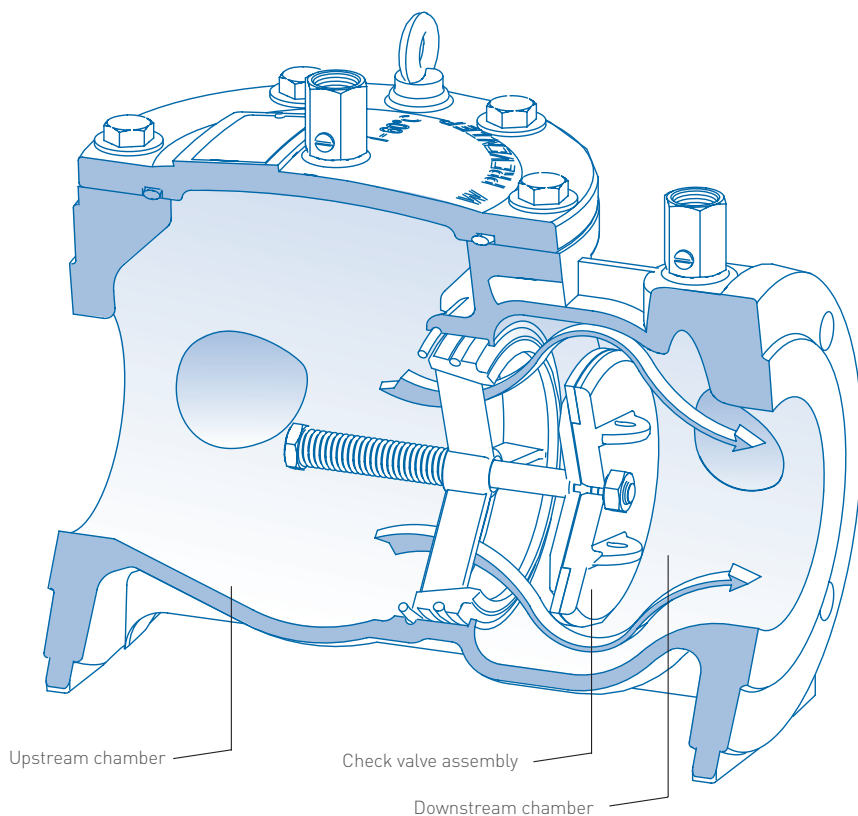

PRINCIPLE OF OPERATION

Under dynamic flow conditions

Pressure builds up in the upstream chamber before the check valve assembly. When pressure is sufficient (minimum of 7 kPa) check valve assembly will open allowing flow into the system pipe work.

Under backpressure conditions

(Premises pressure is greater than supply pressure)
Water pressure in system pipe work and spring pressure force the check valve assembly closed.

Under backsiphonage conditions

(Negative supply pressure in main supply)
Water pressure in the upstream chamber before the check valve assembly will dissipate and the check valve assembly will close under spring pressure.

VALVCEO BACKFLOW PREVENTERS

FIGURE SC03

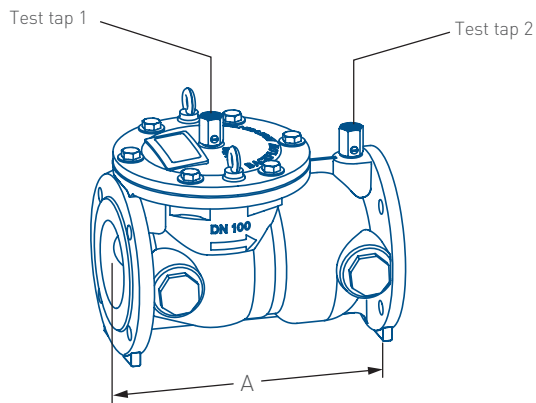

Note: Valve only (VO) illustrated.

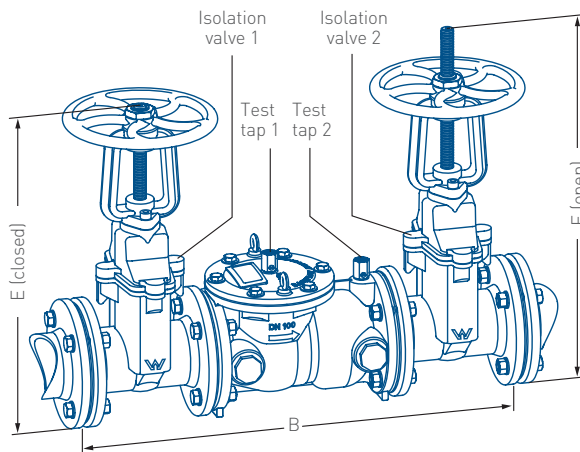

Note: Resilient seated gate (RSGV) valve arrangement illustrated.

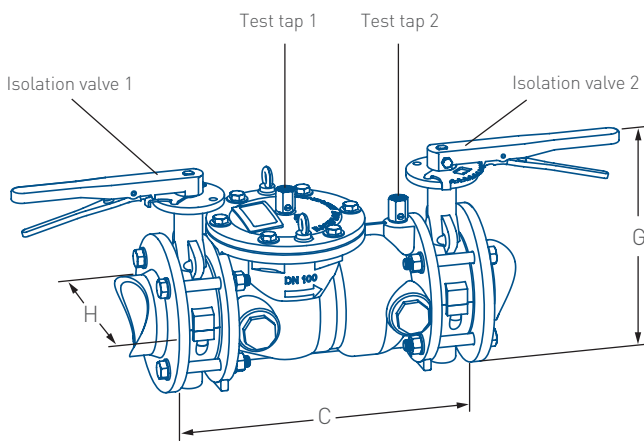

Note: Butterfly valve (BFV) arrangement illustrated.

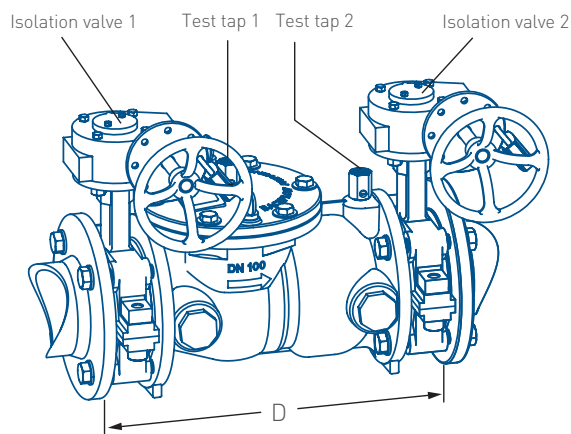

Note: Gear operated butterfly (G/OP) arrangement illustrated.

DIMENSIONS mm

Valve size				Mass kg			
DN	A	B	C/D	VO	RSGV	BFV	G/OP
80	400	815	492	19	84	31	42
100	420	885	525	31	115	50	60
150	500	1040	612	68	178	92	103

NOTE

Dimensions are nominal to ± 1 mm

Butterfly valve actuators change from handles to gear operators on valve sizes DN 150 and above.

Gear operation actuators available on request for butterfly valve arrangement.

Lockable actuators available on request.

VO = Mass of valve only.

RSGV = Mass of complete arrangement with resilient seated gate valves.

BFV = Mass of complete arrangement with butterfly valves.

G/OP = Mass of complete arrangement with gear actuated butterfly valves.

VALVCEQ BACKFLOW PREVENTERS

FIGURE SC03

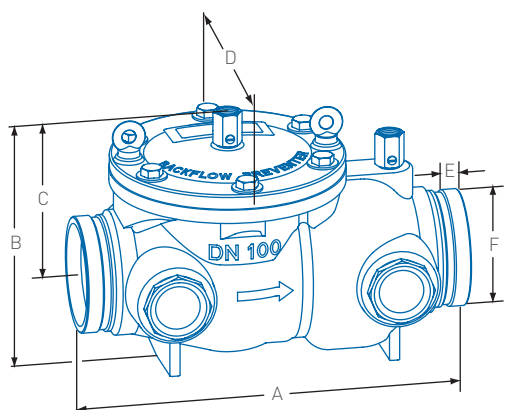

Note: valve only (VO) illustrated.

DIMENSIONS mm

Valve size							Mass
DN	A	B	C	D	E	F	kg
100	380	252	165	230	15.9	114.3	23
150	450	350	220	300	15.9	168.3	46

TYPICAL FLOW CHARACTERISTIC GRAPHS

16 kPa standard spring configuration DN 80 - 100 - 150

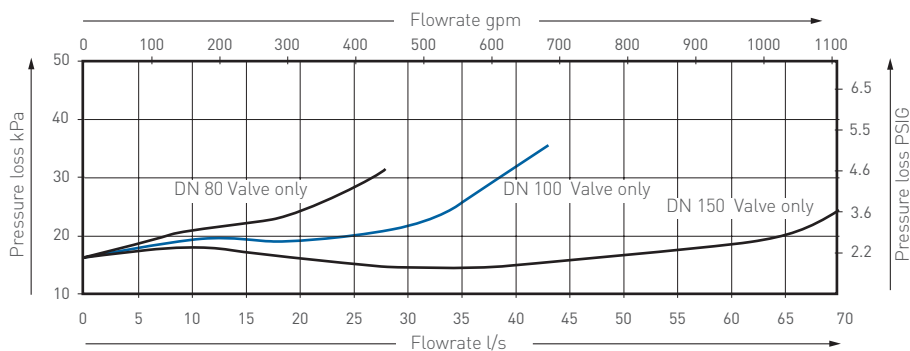

50 kPa optional spring configuration DN 80 - 100 - 150

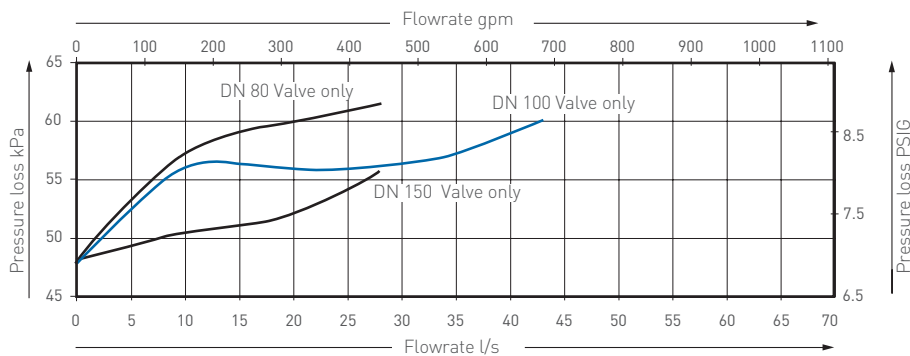

VALVCEQ BACKFLOW PREVENTERS

FIGURE SC03

SELECTION GUIDE

Example:	100	SC03	C	FS	BF
Valve size DN					
Figure no.					
End connections					
C	Flanged AS 4087				
E	Flanged AS 2129				
R/G	Roll grooved AS 2638				
	Alternative flange drillings may be available on request				
Assembly					
VO	Valve only				
FS	Fire service (supplied without strainer)				
Isolation					
BF	Butterfly valves				
BF G/Op	Butterfly valves gear actuated				
BF G/Op L	Butterfly valves gear actuated lockable				
RSGV	Resilient seating gate valves				

NOTE

All Emerson isolation valves come with the provision for locking.

TROUBLESHOOTING GUIDE

Symptom	Cause	Remedy
First check valve not holding tight (reading approaches zero without holding)	<ol style="list-style-type: none"> 1. Debris fouling the check valve seal. 2. Check valve seal damaged or perished. 3. Check valve O-ring damaged. 4. Check valve stem O-ring damaged. 5. Check valve seal ring damaged. 	<ol style="list-style-type: none"> 1. Inspect, clean, reverse or replace check seal. 2. Inspect and replace check valve seal. 3. Inspect and replace O-ring. 4. Inspect and replace O-ring. 5. Replace first check valve assembly.
Check valve holding below 7 kPa	<ol style="list-style-type: none"> 1. Debris fouling the check valve seal. 2. Check valve seal damaged. 3. Check valve spring memory loss or damaged. 4. Check valve stem O-ring damaged. 	<ol style="list-style-type: none"> 1. Inspect, clean, reverse or replace check seal. 2. Inspect and replace check valve seal. 3. Replace first check valve assembly. 4. Check valve stem O-ring damaged.

VALVCHEQ BACKFLOW PREVENTERS

FIGURE SC03

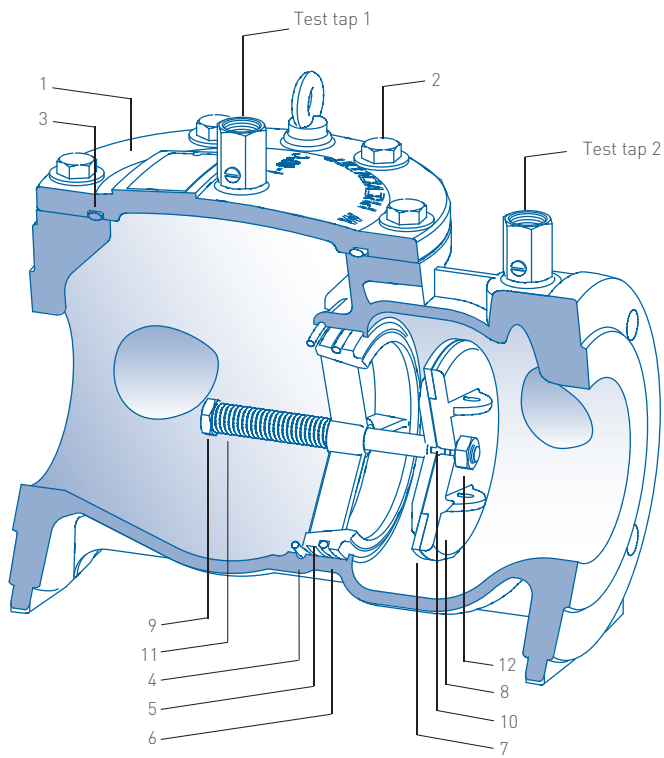

PARTS LIST

No.	Description
1	Cover plate
2	Cover plate bolts
3	Cover plate O-ring
4	Check valve circlip
5	Check valve seal ring
6	Check valve O-ring
7	Check valve seal
8	Check valve disc
9	Check valve stem
10	Check valve stem O-ring
11	Check valve spring
12	Check valve retaining nut

VALVCHQ BACKFLOW PREVENTERS

FIGURE SC03

Complete safety and maintenance instructions for testable single check valve

MAINTENANCE AND TESTING REQUIREMENTS

Test after initial installation and annually for the life of the valve or service. Maintain in a working order and inspect for operational function at intervals not exceeding twelve months. The functions are to be carried out by authorized licensed backflow testers.

DISASSEMBLY INSTRUCTIONS

As described in the safety precautions, slowly close isolation valves and the open test taps 1 and 2 to exhaust line pressure. Remove cover plate bolts (2) and washers. Remove cover plate (1) and cover plate O-ring (3). With a screwdriver remove check valve assembly circlip (4) utilizing cavity recess in the body casting.

NOTE

Please take care and do not chip FBE coating with screwdriver. To remove check valve assembly pull check valve stem/spring (9 and 11) out and then upwards through the top entry of the valve. Check valve assembly, please use the following steps to access check valve seal (7). Using two spanners, fit one spanner to the check valve stem head (9) and the other to the check valve retaining nut (12), turn check valve retaining nut anti-clockwise and remove. Remove check valve disc (8), to expose the check valve seal (7) for servicing or replacement.

NOTE

When reassembling:

- Clean and lubricate all O-rings.
- Check valve seal (7) must be clean, free of any greases, moisture and debris to ensure a positive seal.

SAFETY PRECAUTIONS

In every instance of installation or removal from the pipeline, ensure the line is not pressurized and any hazardous liquid is drained away. Slowly close both isolating valves and then open test taps 1 and 2 to exhaust line pressure.

VALVCHEQ BACKFLOW PREVENTERS

FIGURE SC03

Recommended specifications for testable single check valve



- Main valve shall be manufactured in accordance with AS/NZS 2845.1.
- Main valve shall be constructed from ductile iron and FBE coated to AS/NZS 4158.
- All internals shall be constructed from stainless steel and to have a pressure rating of PN 16 and a temperature rating of 60°C.
- Main valve body shall not form part of the wetted check valve sealing area or mechanism.
- All internal components and elastomer seals shall be accessible through a top entry point of the main valve to allow inline maintenance.
- Valve test points shall also be fitted with BSPT threads to allow testing to AS/NZS 2845.3.
- Main valve to have flanged connections in accordance with AS 4087 or AS 2129 or roll grooved ends to AS 2638.

VCTDS-02936-EN © 2018, 2025 Emerson. All rights reserved 04/25. The Emerson logo is a trademark and service mark of Emerson Electric Co. ValvCheQ is a mark of an entity in the Emerson family of businesses. All other marks are the property of their respective owners.

Neither Emerson nor any of its affiliated entities assume responsibility for the selection, use or maintenance of any product. Responsibility for proper selection, use, and maintenance of any product remains solely with the purchaser and end user.

The contents of this publication are presented for informational purposes only, and while every effort has been made to ensure their accuracy, they are not to be construed as warranties or guarantees, express or implied, regarding the products or services described herein or their use or applicability. All sales are governed by our terms and conditions, which are available upon request. We reserve the right to modify or improve the designs or specifications of such products at any time without notice.