

MetCheck Backflow Preventers

Model MetCheckDCV

Double Check Valves suitable for Medium and low hazard-rated applications.

Features



316 Stainless Steel Body for superior Corrosion Resistance.

Designed & Manufactured in accordance with AS/NZS 2845.1.

Australian Made and Manufactured

Every valve is tested and tracked using unique serial numbers.

For Horizontal & Vertical installations.

Coupling design allows for easy servicing.

General Application

The MetCheck DCV valve safeguards potable water from contamination by preventing back siphonage and backpressure. It is ideal for use in medium & low-hazard applications and is designed for reliability. It also ensures compliance with stringent water safety standards.

Technical Data

Size Range: DN65 – DN150

Temperature Rating: 1°C to 60°C

Working Pressure: PN16

Flanged Connections: AS4087 PN16 & AS2129 Table E

MetCheck Backflow Preventers

Model MetCheckDCV

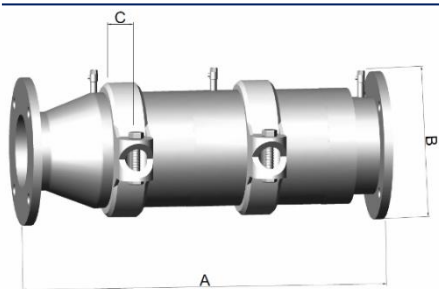

1 Valve Only Illustrated

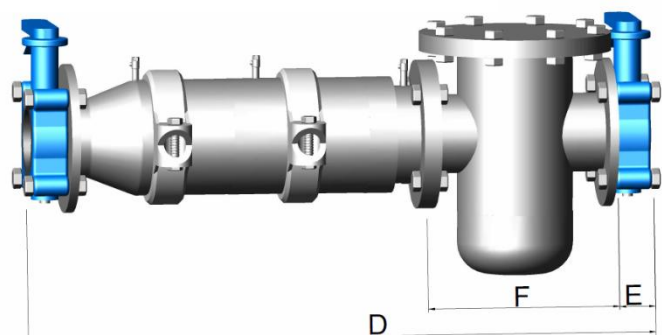

2 Complete Butterfly valve arrangement (BFV) illustrated

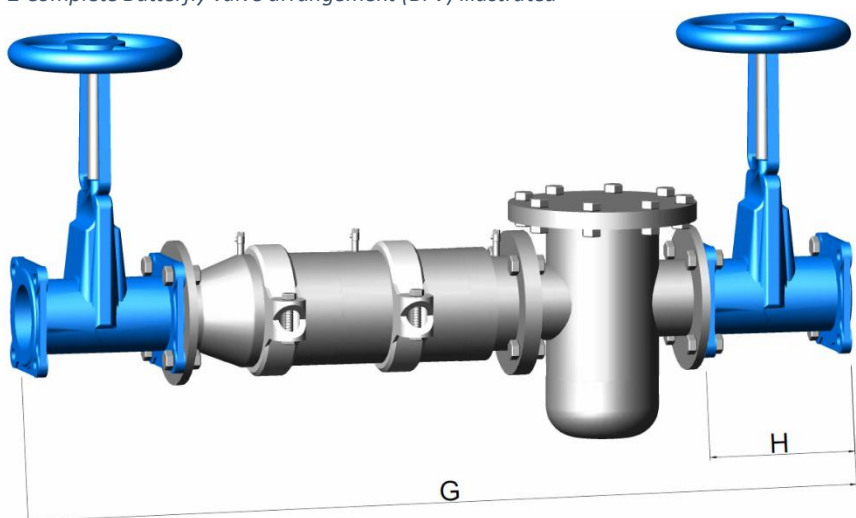

3 Complete Resilient seated gate valve arrangement (RSGV) illustrated.

MetCheck DCV Dimensions

Valve Size (DN)	A(mm)	B (mm)	C (mm)	D (mm)	E (mm)	F (mm)	G (mm)	H (mm)	Valve Weight
65	535	280	280	828	45	200	1124	190	25kg
80	535	280	280	828	45	200	1150	203	25kg
100	535	280	280	902	52	260	1262	229	25.5kg
150	685	420	420	1180	56	380	1608	267	55kg

MetCheck Backflow Preventers

Model MetCheckDCV

Typical Flow Characteristic Graphs

DN100 Valves

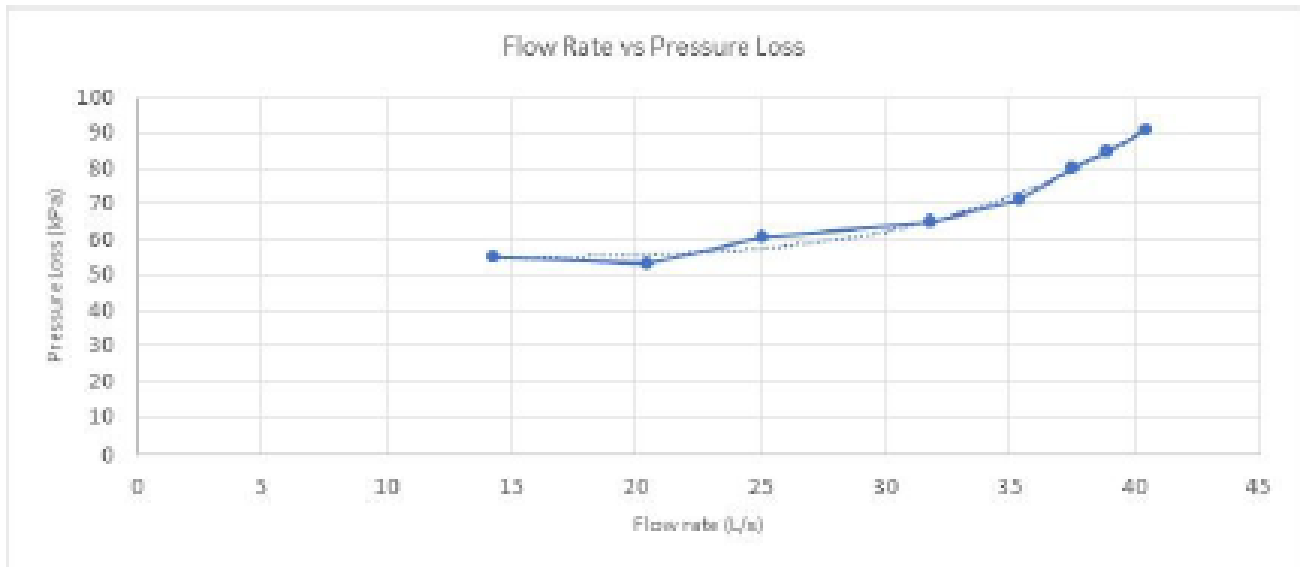

DN150

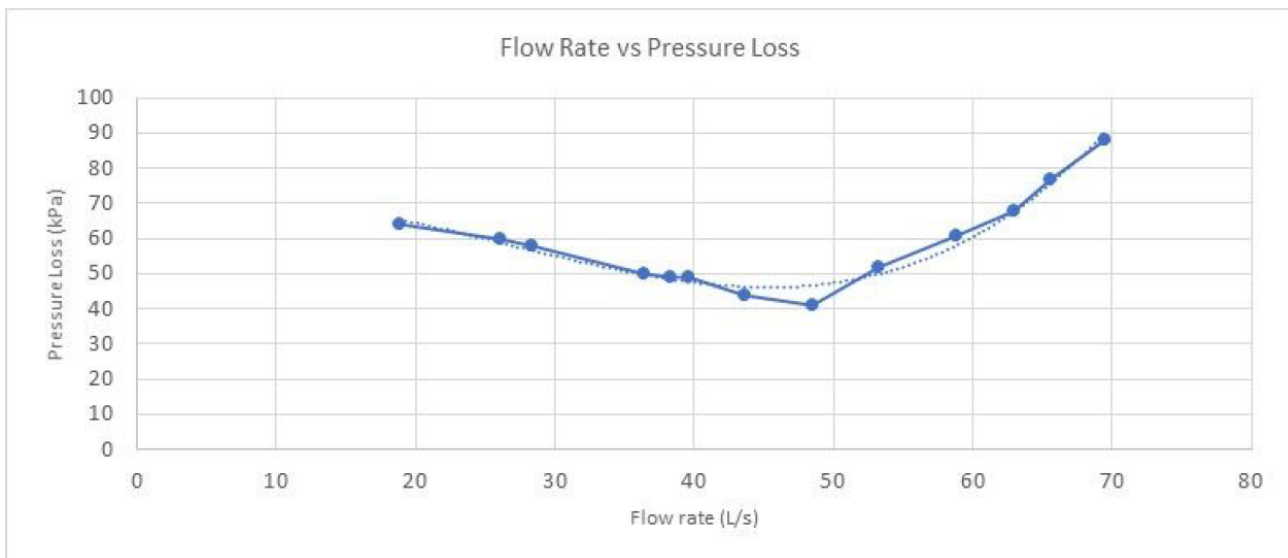

MetCheck Backflow Preventers

Model MetCheckDCV

Installation Instructions:

- MetCheck & MiniMet Valves to be installed by a licensed plumber. Appropriate PPE (Personal Protection Equipment), should be worn by those installing.
- All site risk assessments should be carried out before attempting to install. Installation should be carried out in accordance with AS3500.1, the plumbing and drainage code.
- The MetCheck & MiniMet should be installed in accordance with the direction of flow arrow, relative to the direction of flow of the water. All end connection bolts should be tightened appropriately to overcome leaks.
- Minimum clearance: 300mm. Minimum Clearance from the Bottom of the valve.
- Isolation valves should be installed immediately upstream and downstream of MetCheck's and MiniMet's.
- Strainers are not normally used in main pipelines for fire situations.
- Dual-use fire and domestic installs may have an option inline strainer to protect the check valve componentry.
- High-hazard installs require the use of an inline strainer to protect the check valve componentry. This is to be installed before the RPZ device and after the upstream isolation valve.

Commissioning Instructions:

- MetCheck & MiniMet Valves should be installed by a licensed plumber, with a license endorsed for backflow prevention.
- Commissioning and testing should be conducted in accordance with AS2845.3 Backflow Prevention Devices Field Test.
- Commissioning should be carried out after installation and prior to allowing normal water flow through the valve for consumption use.

Electrolysis & Earthing Requirement:

- All stainless steel MiniMet and MetCheck valves must be earthed to ground at installation and commissioning.
- Failure to correctly earth the valve may result in electrolysis damage, which is not covered under warranty.

Maintenance Instructions:

MetCheck & MiniMet Valves should be maintained by a licensed plumber, with a license endorsed for backflow prevention.

Any commissioning and testing after maintenance, should be conducted in accordance with AS2845.3-2010, by a licensed plumber

MetCheck Backflow Preventers

Model MetCheckDCV

Maintenance is based upon the need for maintenance determined by the annual testing standards as per AS2845.3- 2010.

If the main check valve does not meet the minimum test requirements as per AS2845.3- 2010, then the fault should be found and rectified.

Fault Finding

If the differential pressure is holding, but below the differential pressure pass rate, typically the check module spring has become weak. If the differential pressure drops to zero, typically the check module rubber seals are leaking.

Identifying which check valve needs maintenance, the individual check module should be removed, and parts cleaned or replaced as necessary.

Often a good flush at high flow will clear any lingering debris, and may fix the problem. Retest after flushing.

Maintaining the 1st and 2nd Check Modules:

When performing maintenance on the Metcheck RPZ valves, it is important to first remove the Relief valve hose connection, to allow the bodies to move separately.

For maintenance on the main check modules, remove the Victaulic roll groove fittings.

Once the couplings are removed, slide the sealing ring to one side of the joint.

Inside the MetCheck RPZ, the center vessel and inlet sides contain the check modules. It is crucial to support the valve during this process so that the centre vessel does not drop to the ground and cause any damage.

By removing the Centre vessel this will expose both the 1st & 2nd check modules.

Locate the circlip and spacer at the back end of the module, and remove both.

Pull out the check module. This should come out by hand but may require a slight tap from the front of the check body.

If the check module needs to be maintained, remove the four nuts at the back of the check module using a **ring spanner** (A This will prevent the nuts from distortion and allow for them to be re-installed once maintenance is complete).

Once the four nuts have been removed, maintenance can now be performed on the check module.

Reassembly is the opposite of disassembly.

MetCheck Backflow Preventers

Model MetCheckDCV

Spare Parts:

1st & 2nd Checks:

- 1st or 2nd Check Rubber Rebuild Kit Includes: Check Disc, Seat O-Ring and Cover O-Ring
- O-Ring seals for Check Modules.
- Complete module, 15kpa nominal
- Complete module, 50kpa nominal
- Circlip
- Spacer