

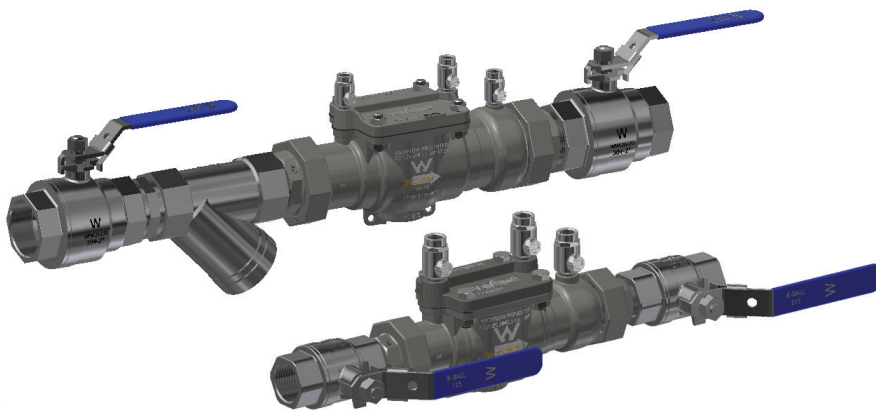

VALVCHEQ BACKFLOW PREVENTERS

FIGURE DC03

Double check valves for medium hazard rated applications
BSP screwed connections



GENERAL APPLICATION

The DC03 provides protection from both backsiphonage and backpressure of the potable water supply from contamination in medium hazard applications.

TECHNICAL DATA

Size range: DN 15 to 50
Temperature rating: 1°C to 90°C
Working pressure: PN 16
End connections: BSPT screwed AS 1722
Alternative threaded connections may be available on request.

FEATURES

- Full stainless steel assembly for superior corrosion resistance.
- No lead product assembly.
- Lightweight compact design.
- In-line and on-site serviceable.
- No special tools required for servicing.
- Approved for hot water service up to 90°C.
- Maintenance friendly with one seal kit suitable for six valves.
- Designed and manufactured in accordance with AS/NZS 2845.1.
- Straight through flow path for maximum flow coefficient.
- Top entry allows all parts to be accessed easily.
- Fully restrained check valve assemblies for unrivalled safety.
- Every valve is bench tested and tracked with unique serial number.
- All internal components are repairable or replaceable.
- Conforms to testing requirements of AS/NZS 2845.3.
- Lockable isolation valves included on standard assemblies.
- Anti-tamper test taps.
- Unique "ring and tail" connections conforming with Australian and International standards replacing conventional compression fittings.
- All internal and external bolting is stainless steel.
- Design conforms to all major international standards.
- Installations can be vertical and horizontal.

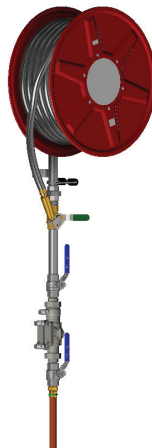

AS/NZS 2845.1 Lic WMKA 1324
SAI Global

VALVCEQ BACKFLOW PREVENTERS

FIGURE DC03

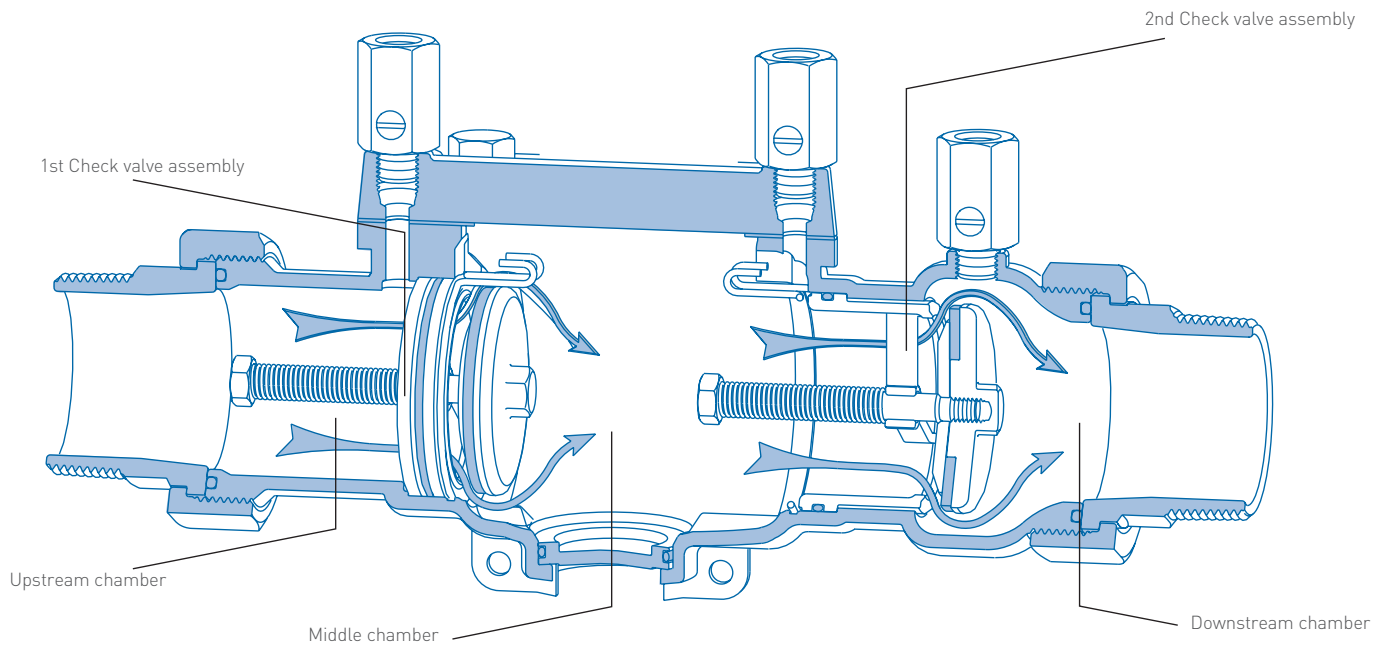

PRINCIPLE OF OPERATION

Double check valve consists of two independently acting non-return valves in series. They are arranged to be force-loaded in the closed position.

Under dynamic flow conditions:

Water enters upstream chamber before the 1st check valve assembly. When water pressure is sufficient (minimum of 7 kPa) 1st check valve assembly will open allowing flow into and fill the middle chamber.

Once the middle chamber is full and pressurized (minimum of 7 kPa), the 2nd check valve assembly will open allowing flow through the down stream chamber.

Under the condition of backpressure:

(Premises pressure is greater than supply pressure)

Water pressure in down stream chamber and spring pressure force the 2nd check valve assembly closed.

Under the condition of backsiphonage:

(Negative/low supply pressure in mains supply)

Water pressure in the up stream chamber before the 1st check valve assembly will dissipate and 1st check valve assembly will close under spring pressure.

VALVCHEQ BACKFLOW PREVENTERS

FIGURE DC03

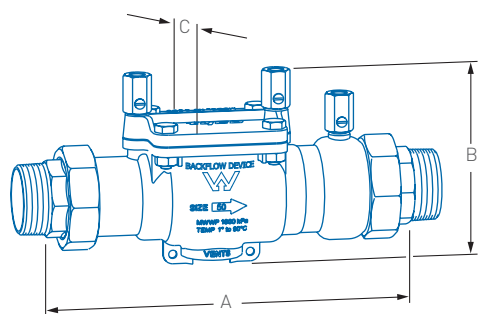

Note: Valve only (VO) illustrated.

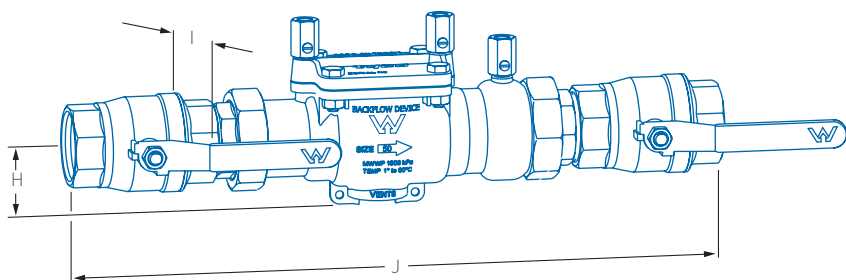

Note: Fire service (FS) arrangement illustrated.

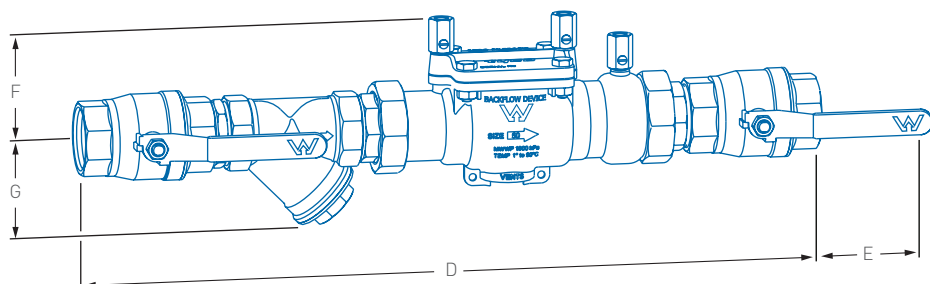

Note: Complete (CO) arrangement illustrated.

DIMENSIONS mm

Valve size DN	A	B	C	D	E	F	G	H	I	J	Mass kg		
											VO	FS	CO
15	233	131	68	432	65	86	40	45	80	353	2.6	3.1	3.4
20	233	131	68	462	65	86	48	45	92	369	2.6	3.3	3.8
25	233	131	68	512	68	86	56	45	96	395	2.6	4.1	4.7
32	312	160	98	638	72	99	64	61	125	508	6.3	8.0	9.3
40	312	160	98	658	87	99	73	61	131	524	6.3	8.5	10.0
50	312	160	98	734	97	99	89	61	143	565	6.3	10.2	11.9

NOTE

Dimension are nominal to ± 1 mm.

VO = Mass of valve only.

FS = Mass of fire service arrangement (no strainer).

CO = Mass of complete arrangement with ball valves.

VALVCEQ BACKFLOW PREVENTERS

FIGURE DC03

TYPICAL FLOW CHARACTERISTIC GRAPHS

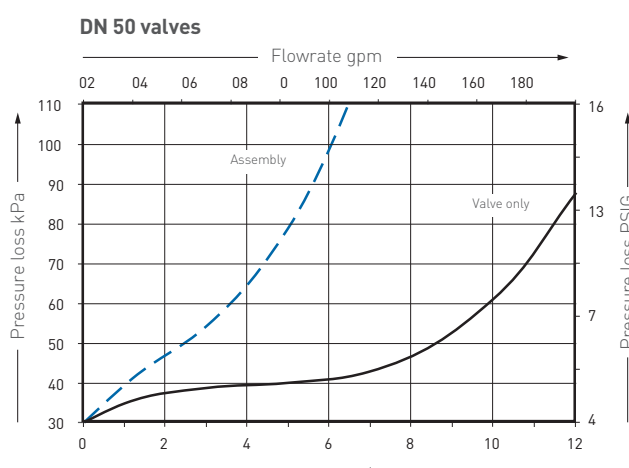
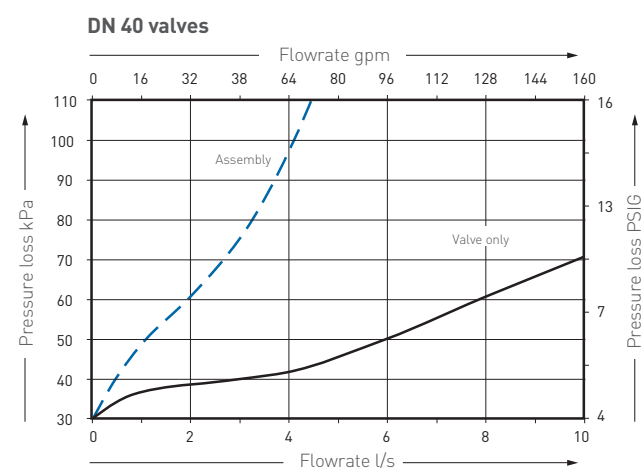
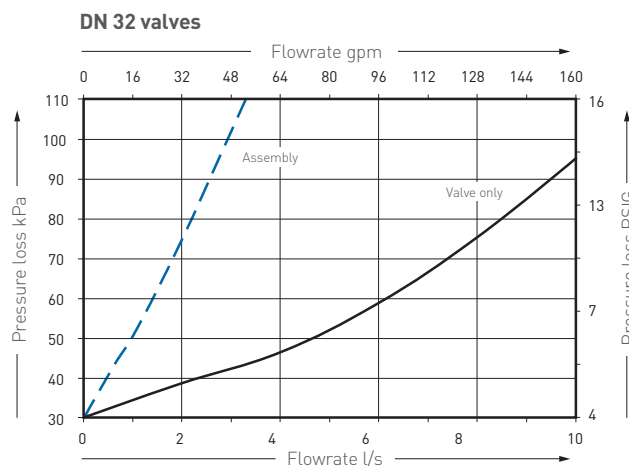
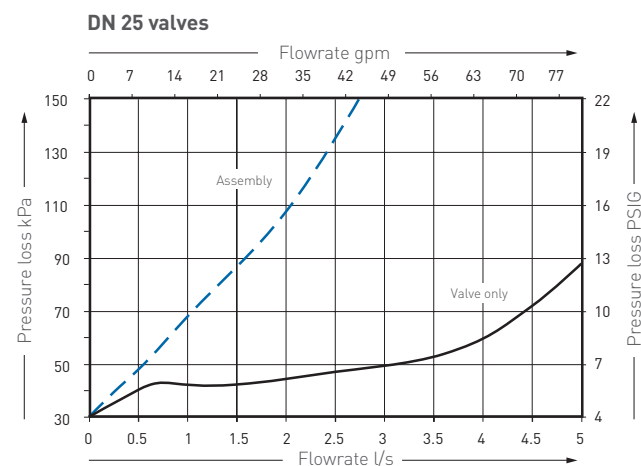
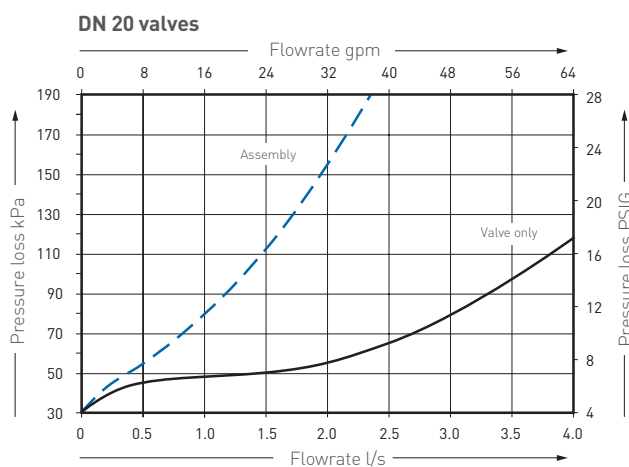
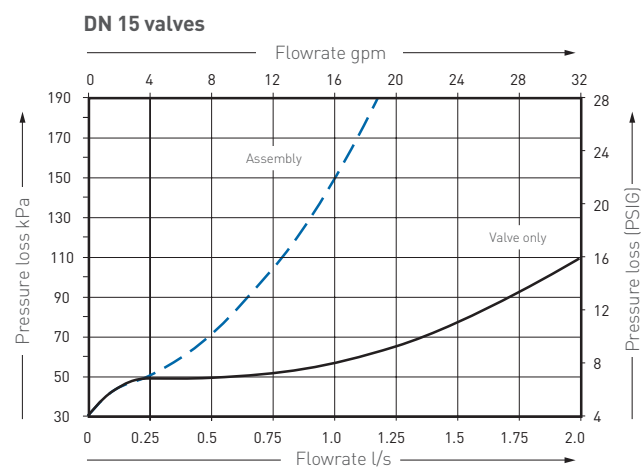

NOTE

- — — Complete valve assembly
- — — Valve only

VALVCEQ BACKFLOW PREVENTERS

FIGURE DC03

SELECTION GUIDE

Example	50	DC03	BSP	CO
Valve size DN				
Figure no.				
End connections				
BSP Screwed AS 1722 Alternative threads may be available on request				
Assembly				
VO Valve only				
CO Complete arrangement with stainless steel ball valves and strainer				
FS Fire Service (no strainer)				

NOTE

All Emerson isolation valves come with the provision for locking.

TROUBLESHOOTING

Symptom	Cause	Remedy
1st check valve not holding tight (reading approaches zero without holding)	<ol style="list-style-type: none"> 1. Debris fouling the check valve seal. 2. Check valve seal damaged or perished. 3. Check valve O-ring damaged. 4. Check valve seal ring damaged. 	<ol style="list-style-type: none"> 1. Inspect, clean, reverse or replace check seal. 2. Inspect and replace check valve seal. 3. Inspect and replace O-ring. 4. Replace first check valve assembly.
1st check valve holding below 7 kPa	<ol style="list-style-type: none"> 1. Debris fouling the check valve seal. 2. Check valve seal damaged. 3. Check valve spring memory loss or damaged. 	<ol style="list-style-type: none"> 1. Inspect, clean, reverse or replace check seal. 2. Inspect and replace check valve seal. 3. Replace first check valve assembly.
2nd check valve not holding tight (reading approaches zero without holding)	<ol style="list-style-type: none"> 1. Debris fouling the check valve seal. 2. Check valve seal damaged or perished. 3. Check valve O-ring damaged. 4. Check valve seal ring damaged. 	<ol style="list-style-type: none"> 1. Inspect and clean, reverse or replace check seal. 2. Inspect and replace check valve seal. 3. Inspect and replace O-ring. 4. Replace second check valve assembly.
2nd check valve holding below 7 kPa	<ol style="list-style-type: none"> 1. Debris fouling the check valve seal. 2. Check valve seal damaged. 3. Check valve spring memory loss or damaged. 	<ol style="list-style-type: none"> 1. Inspect, clean, reverse or replace check seal. 2. Inspect and replace check valve seal. 3. Replace second check valve assembly.

VALVCHEQ BACKFLOW PREVENTERS

FIGURE DC03

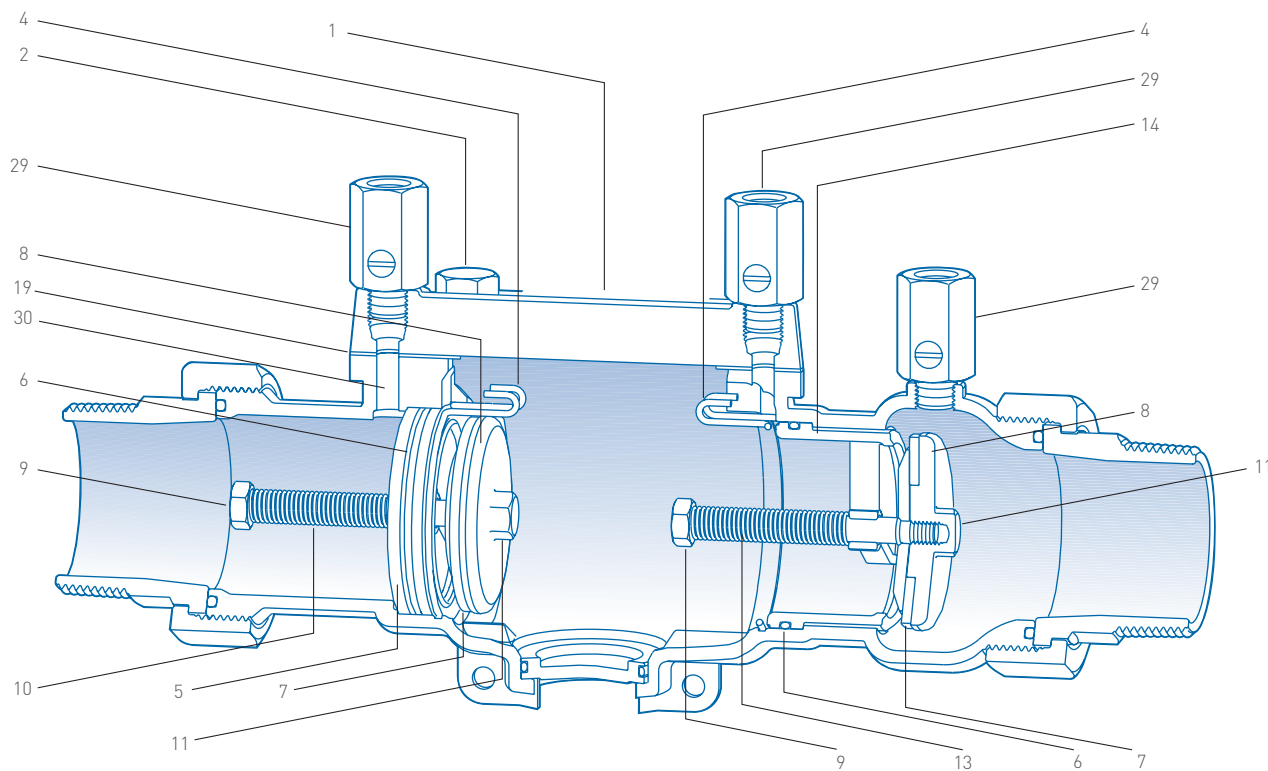

PARTS LIST

No.	Description
1	Cover plate
2	Cover plate bolts
4	Check valve circlip
5	Check valve seal ring
6	Check valve O-ring
7	Check valve seal
8	Check valve disc
9	Check valve stem
10	1st check valve spring
11	Check valve retaining nut
13	2nd check valve spring
14	2nd check valve extended body seal ring
19	Diaphragm
29	Test taps
30	High pressure sensor port

VALVCHQ BACKFLOW PREVENTERS

FIGURE DC03

Complete safety and maintenance instructions for medium hazard devices

MAINTENANCE AND TESTING REQUIREMENTS

Test after initial installation and annually for the life of the valve or service. Maintain in a working order and inspect for operational function at intervals not exceeding twelve months. The functions are to be carried out by authorized licensed backflow testers.

DISASSEMBLY INSTRUCTIONS

Main valve

1. As per safety precautions slowly close isolation valves and the open test taps (29) to exhaust line pressure.
2. Remove cover plate bolts (2).
3. Remove cover plate (1) and diaphragm (19).

Check valve assemblies

1. Utilizing both sets of circlip prongs, squeeze together and pull out 1st and 2nd check valve assembly circlips (4). To remove 2nd check assembly pull check valve stem (9) out then up, bringing the check assembly through the top entry of the valve. To remove 1st check assembly, block high pressure sensor port (30) and slowly crack open inlet isolating valve allowing the water pressure to push the check assembly into the intermediate chamber. Shut off inlet isolating valve and remove check assembly through the top entry of the valve.
2. Both check valve assemblies are mechanically the same, so the same procedure can be used for both assemblies. Fit spanners to the check valve stem head (9) and to the check valve retaining nut (11) turn retaining nut anti-clockwise and remove.
3. Remove check valve disc (8) to expose check valve seal (7) for servicing or replacement.

NOTE

When ready for reassembly, the 2nd check assembly has the longer body.

- Lubricate all O-rings.
- Check valve seal (7) must be clean, free of any greases, moisture and debris upon assembly for a positive seal.

SAFETY PRECAUTIONS

In every instance of installation or removal from the pipeline, ensure the line is not pressurized and any hazardous liquid is drained away. Slowly close both isolating valves and then open test taps (29) to exhausted line pressure.

VALVCHEQ BACKFLOW PREVENTERS

FIGURE DC03

Recommended specifications for medium hazard rated applications

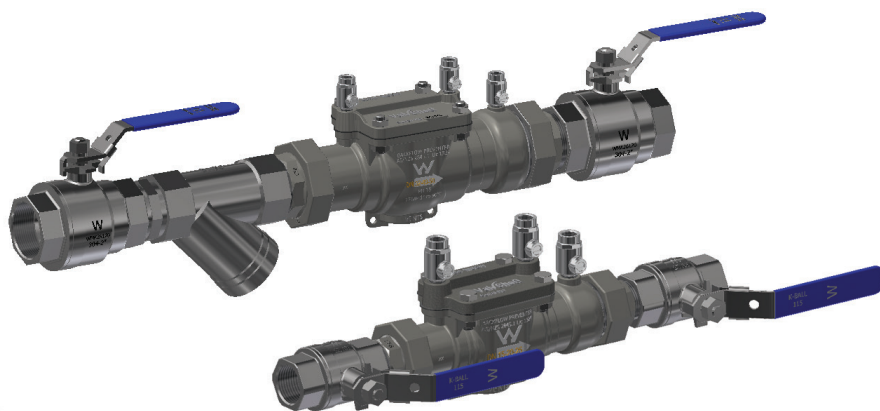

- Valve shall be manufactured and approved to AS/NZS 2845.1.
- The assembly shall be connected with the "ring and tail" to allow easy removal or replacement of the device in accordance with AS/NZS 3500.
- Complete assembly including main valve and internals shall be of stainless steel construction and to have pressure rating of PN 16 and a temperature rating of 90°C.
- All internal parts and elastomers are to be accessible through a top entry point of the main valve to allow inline maintenance.
- Valve shall also be fitted with test points with BSPT threads to allow testing to AS/NZS 2845.3.
- The assembly is fitted with locking mechanism to provide adequate security as standard.

VCTDS-02929-EN © 2015, 2025 Emerson. All rights reserved 04/25. The Emerson logo is a trademark and service mark of Emerson Electric Co. ValvCheQ is a mark of an entity in the Emerson family of businesses. All other marks are the property of their respective owners.

Neither Emerson nor any of its affiliated entities assume responsibility for the selection, use or maintenance of any product. Responsibility for proper selection, use, and maintenance of any product remains solely with the purchaser and end user.

The contents of this publication are presented for informational purposes only, and while every effort has been made to ensure their accuracy, they are not to be construed as warranties or guarantees, express or implied, regarding the products or services described herein or their use or applicability. All sales are governed by our terms and conditions, which are available upon request. We reserve the right to modify or improve the designs or specifications of such products at any time without notice.