

Hasp and Staple suit 003 Pad Lock SUPPLIED SEPARATE.

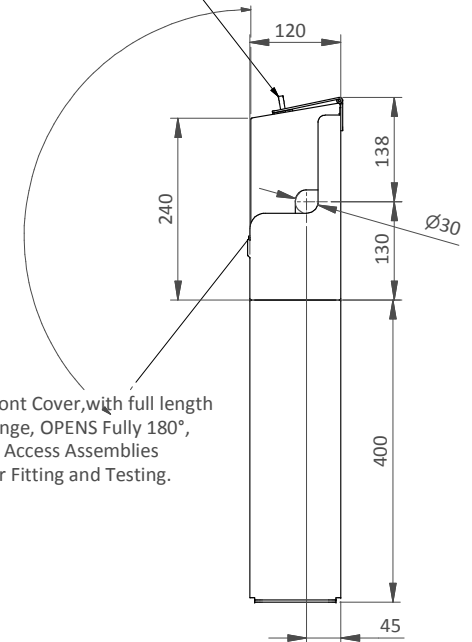

End View

General Notes:-

1. All Material to ASTM A 276 Grade 304 Stainless Steel.
2. Enclosure welded to 400 mm High Leg Mounts, use 4 x Ø12 mm ancohers.
3. All Seams fully Welded, Lower Tundish water tight, Drains to Waste.
4. Drain Outlet suits 40 mm Plug and Waste with Grate Removed, to AS 3500.
5. Hasp and Staple suit 003 Pad Lock NOT supplied.
6. Valves Assemblies, Supplied seperatly, if required.

TABLE
Checked and Sign
Company Name
Order No.

	DCO Loc./Code:	EAGLEFARM	EAG		<small>CONFIDENTIALITY NOTE: This document/program, including the content, is property of Emerson and must be held in strict confidence and properly safeguarded by the recipient at all times. It may not be copied or reproduced, or provided or revealed to any other party, except with prior written authorization of an appropriate officer of Emerson, and any such copy or reproduction must include this disclaimer. The recipient must also be aware that for the purposes for which Emerson has provided it to the recipient, the document must be returned to Emerson upon request. By accepting this document/program, the recipient agrees to the foregoing.</small>	
	DDO Loc./Code:	EAGLEFARM	EAG			
	APPROVALS	NAME	DATE			
	DRAWN BY	M.Pregelj	25.10.18			
	CHECKED BY	DOC	25.10.18	TITLE:	ENC 025 SGL SE 1000 mm long with 400 high Legs	
	APPROVED BY	DOC	25.10.18			
	PRESSURE CLASS	PN 16		SIZE	DRAWING NO.	REV.
	VALVE SIZE	DN 15-25		A2	ENC 25 SGL SE 1000x400	
	FIGURE NUMBER	RP, DC 03		SCALE:	WEIGHT: N/A	SHEET 1 OF 1

ValveCheQ
UNLESS OTHERWISE SPECIFIED, DIMENSIONS ARE IN MILLIMETERS (INCHES); TOLERANCES:
 MILLIMETERS: -- INCHES: [X.#.#] [XX.#.00]
 X.#.# -- [X.#.#] [XX.#.00]
 .XX#.#5 -- [XXX.#.015]
 ANGULAR: ± 0.1°
 REMOVE ALL BURRS & BREAK SHARP EDGES.
 DO NOT SCALE DRAWING. SURFACE ROUGHNESS 3.2µm OR LESS, UNLESS OTHERWISE SPECIFIED.